

## Story Making Kit

Write and illustrate  
your own mini book

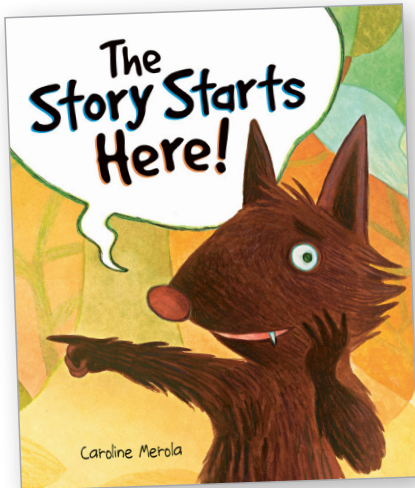

### The Story Starts Here!

By Caroline Merola

ISBN 978-1-77147-079-7  
HC \$17.95 CDN / \$16.95 US

#### Grades

1, 2

#### Reading levels

Fountas & Pinnell: J  
Reading Recovery: 17  
Lexile® Measure: Ad 60L

#### Curriculum links

**Language Arts:**  
Reading Comprehension

## Introduction

In *The Story Starts Here!*, Little Wolf starts things off a little differently. The book begins at the back — fitting for the story of this contrarian day, where Little Wolf insists he'll start with dessert, play the piano with his toes, and wear his pants on his head. Near the end, there's a twist — literally — as readers are invited to flip the book upside down to finish the story and find out the resolution to the problem Little Wolf encounters.

After reading *The Story Starts Here!* aloud in the classroom, use this kit to help students learn the parts of a story inside and out. Each student will finish with his or her own 6-page mini book, each of which will have a twist, too!

## Warm Up Activities

Ask students to describe what happens at the beginning, middle, and end of *The Story Starts Here!*

As a class, make a list of the elements typically found on the front cover of a book. Answers might include the title, the names of the author and illustrator, and an illustration of the main character.

As a class, make a list of the elements typically found on the back cover of a book. Answers might include a description, artwork, and publisher information.

Introduce the six basic stages of a story:

1. Introducing your character
2. Introducing your character's problem
3. Your character tries to solve the problem
4. Your character encounters an obstacle

Then there's a TWIST! A new idea, a discovery, or a change in perspective.

5. The climax: how does the twist help resolve your character's problem?
6. The ending: what's the outcome for your character, now that the problem is solved?

Ask students to come up with a story of their own that follows this pattern. Use the worksheets that follow to bring the story from idea to outline, draft, and then finished book.

# WORKSHEET

## Sequencing Your Story



Fill in this sheet with rough notes about what you'll include on each page of your book. What is a logical sequence of events? What text will be on each page? What kind of illustration should go with it? This is called an outline.

### FRONT COVER

**Title:**

Author's Name: \_\_\_\_\_ Illustrator's Name: \_\_\_\_\_

Art ideas: \_\_\_\_\_

**Page 1:** introduce your character

Text: \_\_\_\_\_  
\_\_\_\_\_  
\_\_\_\_\_

Art: \_\_\_\_\_

**Page 2:** introduce your character's problem

Text: \_\_\_\_\_  
\_\_\_\_\_  
\_\_\_\_\_

Art: \_\_\_\_\_

**Page 3:** your character tries to solve the problem

Text: \_\_\_\_\_  
\_\_\_\_\_  
\_\_\_\_\_

Art: \_\_\_\_\_



# WORKSHEET

## Sequencing Your Story



**Page 4:** your character encounters an obstacle

Text: \_\_\_\_\_  
\_\_\_\_\_  
\_\_\_\_\_

Art: \_\_\_\_\_

**Then there's a TWIST! A new idea, a discovery, or a change in perspective.**

**Page 5:** the climax — how does the twist help resolve your character's problem?

Text: \_\_\_\_\_  
\_\_\_\_\_  
\_\_\_\_\_

Art: \_\_\_\_\_

**Page 6:** the ending — what's the outcome for your character, now that the problem is solved?

Text: \_\_\_\_\_  
\_\_\_\_\_  
\_\_\_\_\_

Art: \_\_\_\_\_

### BACK COVER

Text: \_\_\_\_\_  
\_\_\_\_\_  
\_\_\_\_\_

Art: \_\_\_\_\_



# WORKSHEET

## Sequencing Your Story



Write the words for each page, just as you want them to appear in your book. Write down your final decision about what to draw on each page.

### FRONT COVER

**Title:**

Author's Name: \_\_\_\_\_ Illustrator's Name: \_\_\_\_\_

Art ideas: \_\_\_\_\_

**Page 1:** introduce your character

Text: \_\_\_\_\_  
\_\_\_\_\_  
\_\_\_\_\_

Art: \_\_\_\_\_

**Page 2:** introduce your character's problem

Text: \_\_\_\_\_  
\_\_\_\_\_  
\_\_\_\_\_

Art: \_\_\_\_\_

**Page 3:** your character tries to solve the problem

Text: \_\_\_\_\_  
\_\_\_\_\_  
\_\_\_\_\_

Art: \_\_\_\_\_

# WORKSHEET

## Sequencing Your Story



**Page 4:** your character encounters an obstacle

Text: \_\_\_\_\_  
\_\_\_\_\_  
\_\_\_\_\_

Art: \_\_\_\_\_

**Then there's a TWIST! A new idea, a discovery, or a change in perspective.**

**Page 5:** the climax — how does the twist help resolve your character's problem?

Text: \_\_\_\_\_  
\_\_\_\_\_  
\_\_\_\_\_

Art: \_\_\_\_\_

**Page 6:** the ending — what's the outcome for your character, now that the problem is solved?

Text: \_\_\_\_\_  
\_\_\_\_\_  
\_\_\_\_\_

Art: \_\_\_\_\_

## BACK COVER

Text: \_\_\_\_\_  
\_\_\_\_\_  
\_\_\_\_\_

Art: \_\_\_\_\_

# INSTRUCTIONS: How To Assemble Your Book

Start with a blank book template lying flat in front of you. You'll find that on the next page.

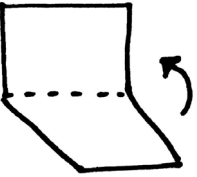
**1.** 

Fold the sheet of paper in half so the short sides meet. Then, unfold it flat again.

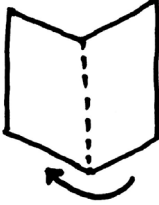
**2.** 

Fold the paper in half so the long sides meet. Then, unfold it flat again.

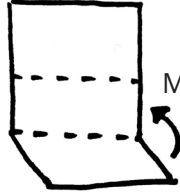
**3.**  Middle

Fold the bottom up to meet the middle. Then, unfold it flat again.

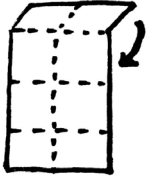
**4.** 

Fold the top down to meet the middle. Then, unfold it flat again.

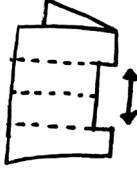
**5.** 

With the side with the black lines face up, fold the paper in half so the long sides meet again. Then, cut a very thin slit right in the middle. Ask your teacher if you need help.

**6.** 

With the slit facing you, hold both sides of the page and open it up until you can see through the slit, making a diamond shape.

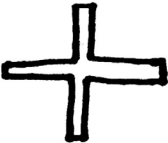
**7.** 

Pull further until the page looks like a plus sign.

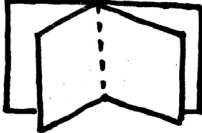
**8.** 

Put it down on a table with "back cover" and "cover" flat against the table.

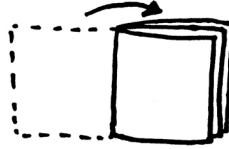
**9.** 

Fold it in half, so the cover is on the outside. If you want, you can tape the open edges to make your book sturdier.

Now that you have a folded book template, you're ready to add your text and artwork and make the finished product!

Made possible with the support of the Ontario Media Development Corporation

Cover			
1	2	3	4
	Back Cover	6	5
			